

Assembly Instructions

Item NO.:

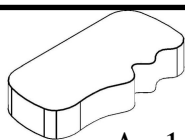

A x1



B x2

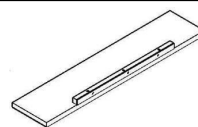

C x2

NO.	DESCRIPTION	QTY		NO.	DESCRIPTION	QTY
D	SCREWS \varnothing 7*28	18		E	Wrench \varnothing 5	1

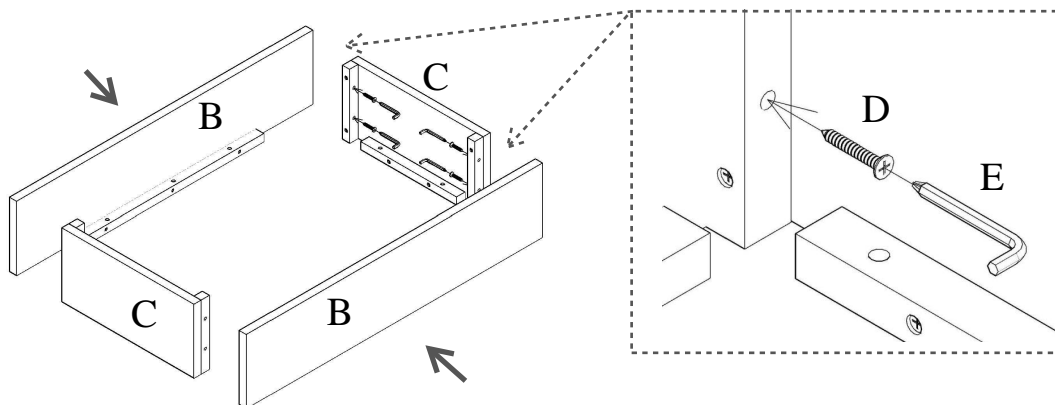

P1

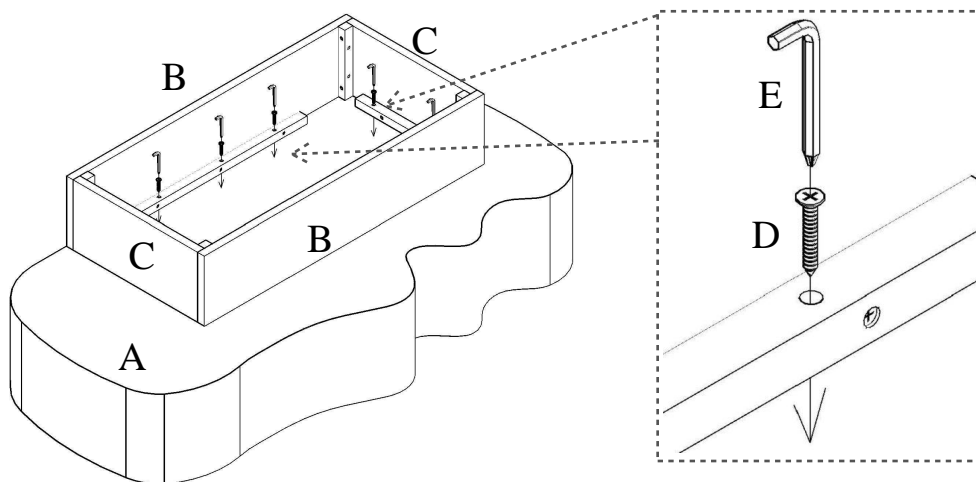

P2

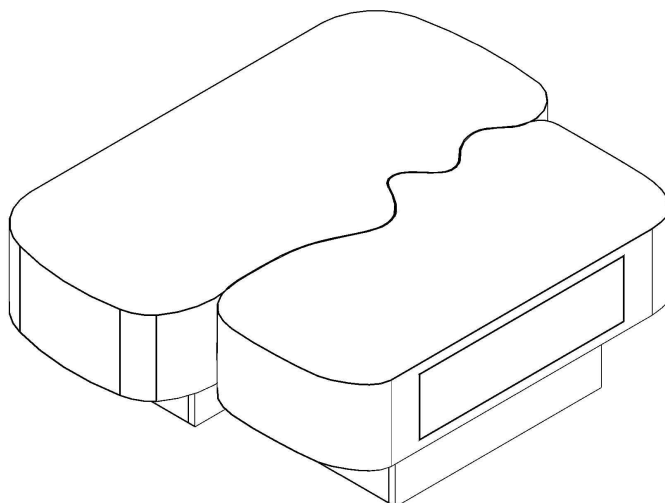

P3